

GROUPS 29, 33, 38, & 40

ALL GROUPS

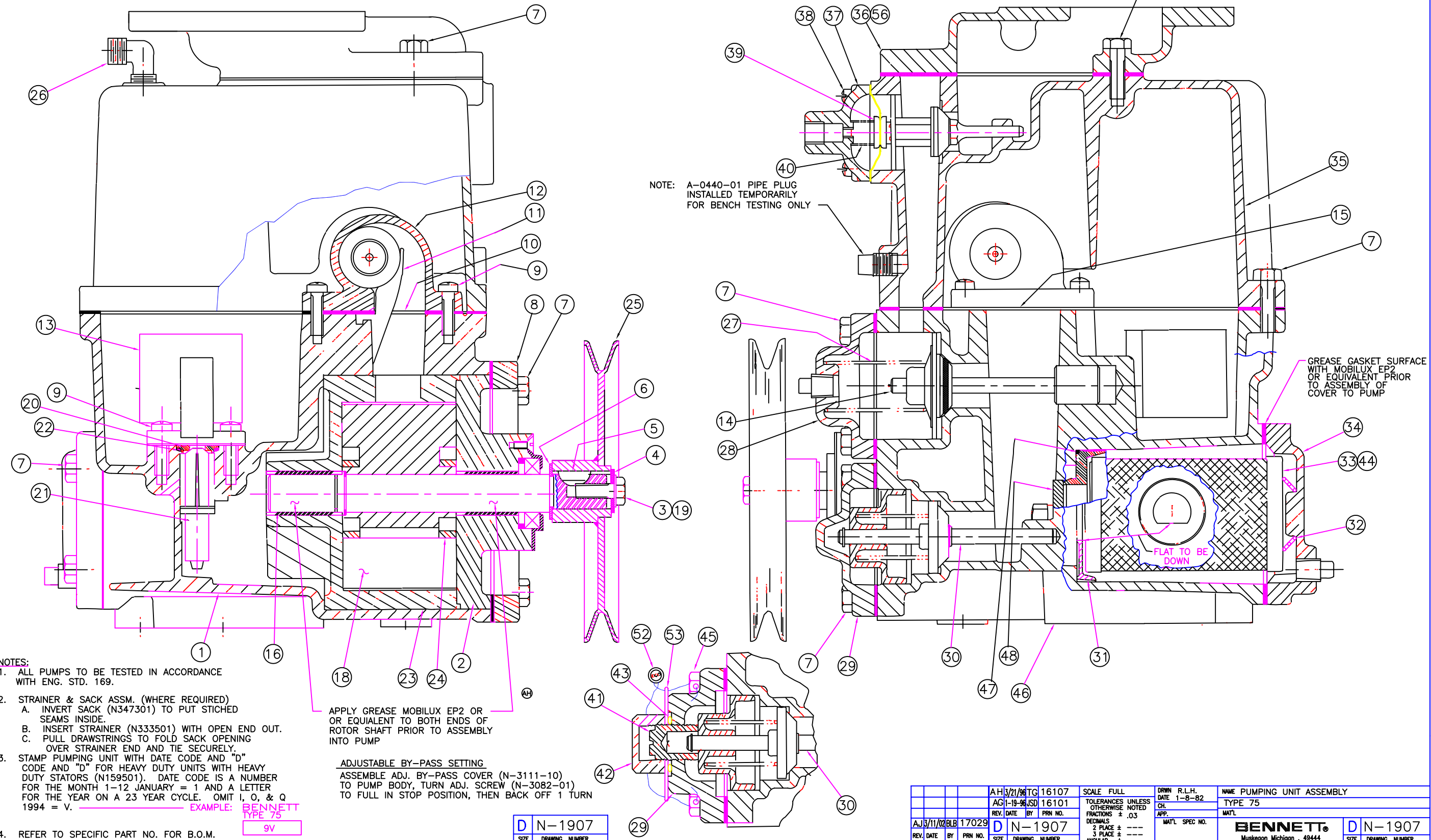

NOTES:

- ALL PUMPS TO BE TESTED IN ACCORDANCE WITH ENG. STD. 169.
- STRAINER & SACK ASSM. (WHERE REQUIRED)
 - INVERT SACK (N347301) TO PUT STICHD SEAMS INSIDE.
 - INSERT STRAINER (N333501) WITH OPEN END OUT.
 - PULL DRAWSTRINGS TO FOLD SACK OPENING OVER STRAINER END AND TIE SECURELY.
- STAMP PUMPING UNIT WITH DATE CODE AND "D" CODE AND "D" FOR HEAVY DUTY UNITS WITH HEAVY DUTY STATORS (N159501). DATE CODE IS A NUMBER FOR THE MONTH 1-12 JANUARY = 1 AND A LETTER FOR THE YEAR ON A 23 YEAR CYCLE. OMIT I, O, & Q
 EXAMPLE: BENNETT TYPE 75 9V
- REFER TO SPECIFIC PART NO. FOR B.O.M.

GROUP	DESCRIPTION
01	STANDARD
02	HEAVY DUTY (CODE D)
03	STD. - PRE PAY
04	HEAVY DUTY PRE PAY
05	HEAVY DUTY (FOR 1 PROD. TWIN)
06	CODE DHX7
07	CODE HX7 STD.
08	TAIWAN CODE 732 W/ADJ. B.P. (563D)
09	CODE 422 & CANADA STD.
10	CANADA PRE PAY STD.
11	BECK STD.
12	CODE HX7-422 & 3700 HX7 STD.
13	SAUDI-ARABIA-STNR & SACK H.D.
14	SAUDI-ARABIA-STNR & SACK HX STD.
15	SAUDI-ARABIA-STNR & SACK (STD.)
16	CODE HX7 (FOR 1 PROD. TWIN) STD.
17	ALGERIA - CODE 382W W/HX7 STD.
18	ALGERIA - CODE 388 W/DHX7
19	BECK CODE D
20	IRAN-STD. HX7, STNR., ADJ. BY-PASS
21	TAIWAN CODE D, ADJ. BY-PASS
22	TBD
23	SAUDI-ARABIA CODE D, HX7, STNR & SACK
24	BENNETT + SAUSER- ADJ. B.P. STANDARD
25	BENNETT + SAUSER- ADJ. B.P. CHK. V. H.D.
26	TAIWAN CODE 743 W/ADJ. B.P., PRE-PAY
27	EGYPT DHX7, STNR., ADJ. B.P.
28	HEAVY DUTY-SATAM-W/ADJ. B.P. & HX.
29	SCH & BACH.-HX,D,ADJ. B.P., W/O FILTER COVER
30	HEAVY DUTY CODE D W/SATAM ATMOS. COVER
31	SAUDI ARABIA-PRE PAY, STNR & SACK (STD.)
32	H.D. W/ADJ. B.P. & FILTER-SCH. & BACH.
33	HEAVY DUTY W/ADJ. B.P. & HX FOR EIN
34	STANDARD DUTY W/SATAM ATMOS. COVER
35	HUNGARY - HEAVY DUTY
36	HUNGARY - STANDARD
37	HUNGARY - 6027
38	FINLAND - W/ADJ. B.P. & HX
39	MATAM - MOROCCO - W/ADJ. B.P. & HX7
40	SCH & BACH. - HX, D, ADJ. B.P., CHK. V.
41	KOREA HEAVY DUTY, ADJ. B.P., SAUDI STNR & SACK, (00P)
42	BENNETT + SAUSER - STNR. ADJ. B.P. CHK.V.
43	BENNETT + SAUSER - STNR. ADJ. B.P. CHK.V.
44	BENNETT + SAUSER - STNR. ADJ. B.P. CHK.V.